

ChemValve[®]

**MODEL 790EB-300
HIGH PERFORMANCE
LINED PLUG VALVE**

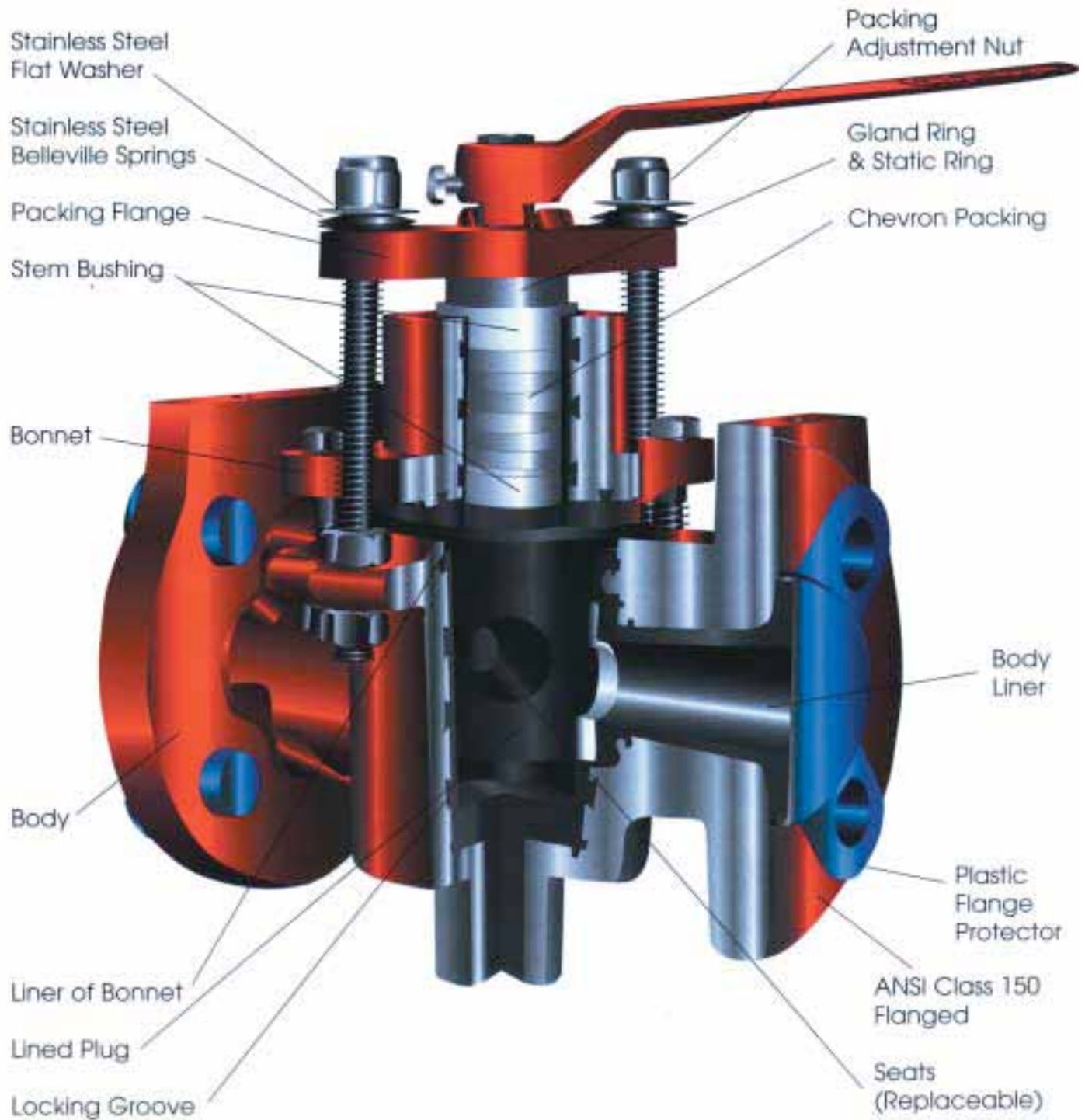



MODEL 790EB-300
HIGH PERFORMANCE LINED PLUG VALVE
FIRST PLASTIC LINED PLUG VALVE
WITH FIELD REPLACEABLE SEATS

- Available in sizes 1" through 6"
- Class 300 ANSI raised face flanged end connection
- Available in Polypropylene, PVDF-Kynar®, PFA, and GRPFA liner materials
- Rated at 640 PSIG from 50°F to 100°F, and 150 PSIG at the temperature capability of the plastic liner
- Rated for full vacuum service
- Chevron TFM packing
- Replaceable seats
- Low turning torques
- Thicker plastic liners (0.125 inches minimum)
- Longer service life

ACTUATION AND INSTRUMENT VALVE ASSEMBLIES

<u>MANUAL</u>	<u>PNEUMATIC</u>	<u>ELECTRIC</u>	<u>ACCESSORIES</u>
Handle	Piston	All Styles	Solenoid Valve
Square Nut	Rack & Pinion		Positioner
"T" - Handle	Diaphragm		Transducer
Extension Handle	Vane		Limit Switches
Gear Operator	Spring Return		Position Transmitter
Chain Wrench			Manual Override
Chain Wheel			

THE MODEL 790EB-300 LINED PLUG VALVE
IS INJECTION MOLDED

Injection molding is a process whereby plastic resin is heated to a melt temperature and injected under pressure into the interior of the Model 790EB-300 plug valve body, bonnet or onto the plug. This process creates a uniformly dense thickness of heavy plastic lining. Also, it is locked into the machined body grooves. The locked-in lining is an excellent feature for vacuum service applications. Other plug valve designs using PTFE as a liner cannot use the injection molding process because PTFE does not melt. During this process, the PTFE can thin and experience stress concentrations, because a PTFE tube must be forced into shape by pressure and temperature, PTFE liners may not be of uniform thickness nor will they be locked in for vacuum service. Thus, injection molding is the superior method of lining valves with plastic.

CHOICE OF LINERS

Model 790EB-300 Plug Valve liner selection is dependent upon the application

MODEL 790EB-300 plug valves can be supplied with Polypropylene, PVDF-Kynar®, PFA, or GRPFA. These are all melt processible resins which are injection molded into the valve body.

Liner selection should be based on the corrosion resistance of the plastic resin to the flowing media at service temperature and pressure. Please consult a corrosion chart for compatibility. Remember, there is no need to use a PFA lined valve when Polypropylene will perform just as well.

PPL

POLYPROPYLENE

Polypropylene is a thermoplastic resin exhibiting an excellent balance of corrosion resistance and economy. When injection molded into a Model 790EB-300 plug valve, it provides an excellent low cost product for many applications, as well as HCl applications and in the water and waste water treatment industry. The suitability of polypropylene is highly dependent on service temperature. Polypropylene is especially good in ambient temperature applications. This liner has been tested in 37% HCl and approved. The maximum temperature rating of the 790EB-300 Polypropylene lined plug valve is 225 degrees F.

PVDF

KYNAR® (Poly-vinylidene fluoride)

PVDF is a strong hard fluorocarbon resin which is thermally stable, non-toxic and has excellent chemical resistance. PVDF is especially well suited to weak corrosives and slurry service applications found in bleach plants of pulp and paper mills. PVDF is the material of choice for liquid and gaseous chlorine and other halogen containing chemicals. The suitability of PVDF in a given corrosive service is highly dependent on temperature. In some cases, PVDF can be substituted for a PFA lining. In abrasive applications, PVDF will work better than PFA, due to its resistance to erosion, provided it is chemically compatible with the service. The maximum temperature rating of the 790EB-300 PVDF lined plug valve is 275 degrees F.

PFA

(Perfluoroalkoxy)

PFA is a higher temperature resin with the same outstanding chemical inertness as PTFE. Due to its chemical composition, PFA retains a high amount of mechanical strength at elevated temperatures. The maximum temperature rating of the Model 790EB-300 PFA lined plug valve is 400 degrees F.

GRPFA

Glass-Reinforced PFA

Glass Reinforced PFA is a liner material which combines the corrosion resistance of PFA at elevated temperatures with the abrasion resistance quality of PVDF. GRPFA is unsurpassed in high temperature slurry applications where virgin PFA or PTFE lined valves cannot withstand erosion. The maximum temperature rating the the Model 790EB-150 GRPFA lined plug valve is 400 degrees F.

MODEL 790EB-300 HIGH PERFORMANCE LINED PLUG VALVE

GLOBE VALVE STYLE CHEVRON PACKING

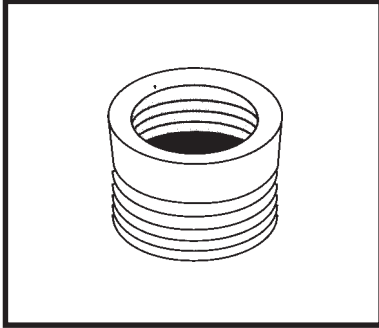

The ChemValve® Model 790EB-300 high performance lined plug valve has adjustable chevron TFM packing like a globe valve. The six ring set is much more substantial than the thin diaphragms used in other lined plug valve designs. If process pressure leaks into one of the packing rings, it will mechanically spread the ring sealing off the leak. This means there is little chance of either corrosive stem leakage onto the bonnet of the valve or fugitive emissions to the atmosphere.

BALL VALVE STYLE REPLACEABLE SEATS

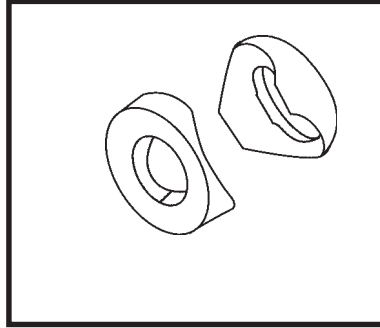

The ChemValve® Model 790EB-300 high performance lined plug valve has replaceable seats like a ball valve, giving it many advantages over other lined plug valve designs. When the seats wear down from multiple cycles, they are easily replaced without removing the Model 790EB-300 plug valve from the pipe line. Other lined plug valves, however, must be discarded and new valve installed. Because our seats take the wear of the plug, the Model 790EB-300 liner lasts longer against the effects of erosion, pressure and temperature. The replaceable seats in the ChemValve® Model 790EB-300 give lower operating torques equating to additional benefits including ease of turning and downsizing of actuators.

PLUG VALVE

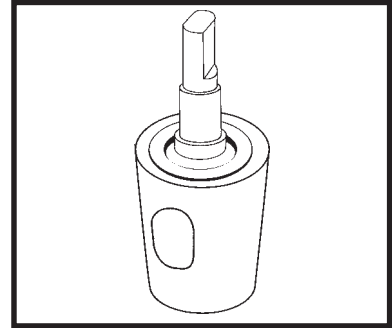

The plug valve is one of the oldest valve designs known to man, but it is still an excellent choice for corrosive and/or erosive applications due to its adjustability. Unlike a fully lined ball valve design which has no facility to stop line leakage, the Model 790EB-300 high performance lined plug valve can be adjusted to stop a leak past the seats while the valve is in service. Furthermore, the adjustment is simple enough to be performed by a plant operator armed with pliers, instead of requiring an experienced valve mechanic with several tools. The packing flange extends perpendicular to the pipeline allowing easy adjustment especially if the valve is actuated. All of these features convert directly into cost savings for the user.

ENGINEERING DATA

TECHNICAL DESCRIPTION

Pressure Class: ANSI CL 300

Size Range: 1" to 6"

End Connection: Raised face flanged

Liner Material: PPL, PVDF, PFA, GRPFA

Liner Thickness: Minimum .125"

Rated for Full Vacuum

External Protection: Water Based Acrylic Urethane
Other Coatings Available

MODEL 790EB BILL OF MATERIALS	
PART	MATERIAL
Body	SEE ****
Bonnet	SEE ****
Packing Flange	Steel**
Plug	Ductile Iron*
Seats	PTFE
Packing	TFM
Gland Ring	304 SS
Static Ring	302 SS
Botling	316 SS
Handle	Steel**

* All Cast Ductile Iron is ASTM-A395

**All Cast Steel is ASTM-A216-WCB

****BODY & BONNET MATERIAL

1", 1 1/2", & 2" - STEEL

3", 4", & 6" - DUCTILE IRON

Size	CV VALUE	BREAK TORQUE (IN./LBS.)
1"	20	450
1.5"	53	630
2"	133	630
3"	247	1350
4"	420	1980
6"	713	3600

NOTE: Above Torques for PTFE Seats

PRESSURE - TEMPERATURE CURVES

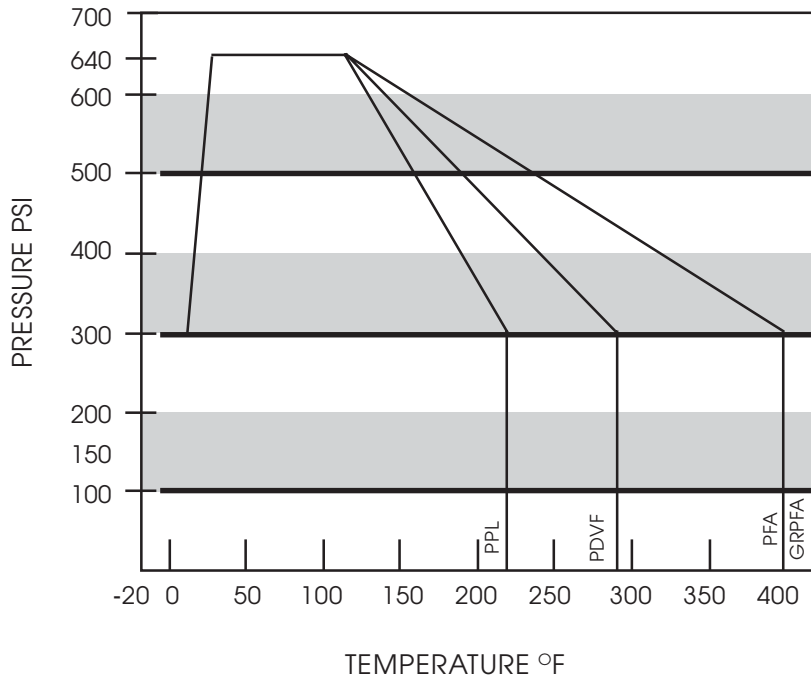

MAX SERVICE TEMPERATURE	
PPL	225°F (107°C)
PVDF	275°F (135°C)
PFA	400°F (204°C)
GRPFA	400°F (204°C)

OUTLINE DIMENSIONS OF MODEL 790EB-300 LINED PLUG VALVE

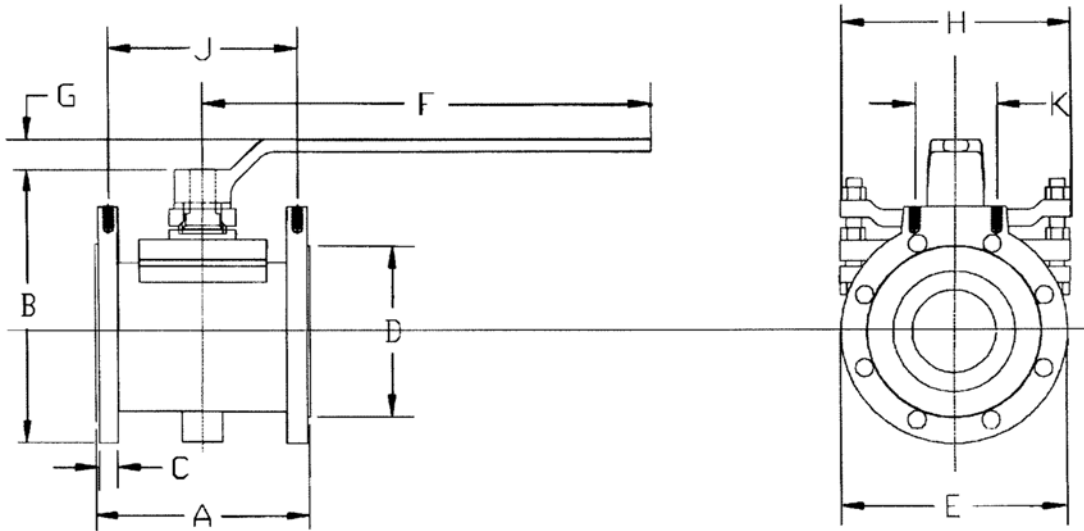

* + Tolerance $\pm 1/16$ "

** Tolerance ± 0.010 "

Nominal Valve Size	A*	B*	C*	D*	E*	F*	G*	H*	Bolt Hole Diam.	Diam. Bolt Circle	Approx. Valve Weight	Mounting Pad			4 Tapped Holes	
												J**	K**	Hole Diam.	Thread	Thread Depth
1"	6.50"	7.12"	0.69"	2.20"	4.88"	10.0"	1.00"	5.63"	0.75"	3.50"	19#	5.55"	1.75"	5/16"	18UNC	7/8"
1.5"	7.50"	7.75"	0.88"	2.88"	6.12"	10.0"	1.00"	7.50"	0.88"	4.50"	31#	6.20"	1.75"	5/16"	18UNC	1"
2"	8.50"	8.51"	0.88"	3.63"	6.63"	10.0"	1.00"	7.50"	0.75"	5.00"	40#	7.30"	2.25"	5/16"	18UNC	1"
3"	11.13"	11.05"	1.09"	5.00"	8.25"	16.00"	0.75"	9.00"	0.88"	6.63"	78#	9.84"	3.50"	3/8"	16UNC	1.125"
4"	12.00"	12.00"	1.40"	6.13"	10.13"	N/A	N/A	9.00"	0.88"	7.88"	118#	10.35"	4.00"	1/2"	13UNC	1.125"
6"	15.88"	15.67"	1.50"	8.50"	12.63"	N/A	N/A	11.25"	0.88"	10.63"	232#	14.00"	4.00"	1/2"	13UNC	1.125"

ChemValve®

website: www.chemvalve.com

27850 Commercial Park Drive
Tomball, Texas 77375

PH: (281) 357-0101

(800) 879-3720

FAX: (832) 255-2261

email: ChemValve@worldnet.att.net