

# OUTLINE DIMENSIONS OF MODEL 880S-150 LINED SPRING ASSISTED BALL CHECK VALVE

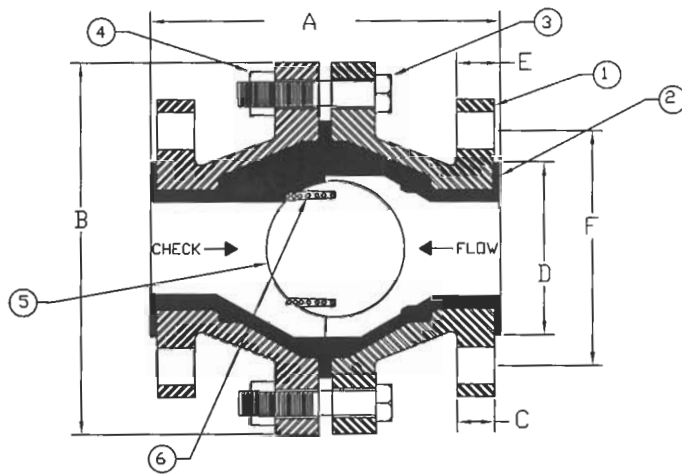

| PART NUMBER  | NOMINAL VALVE SIZE | A     | B      | C<br>APPROX. | D     | E<br>APPROX. | F               |                    |                      | APPROXIMATE WEIGHT - LBS. |      |
|--------------|--------------------|-------|--------|--------------|-------|--------------|-----------------|--------------------|----------------------|---------------------------|------|
|              |                    |       |        |              |       |              | NUMBER OF HOLES | BOLT HOLE DIAMETER | BOLT CIRCLE DIAMETER | VALVE                     | BALL |
| 1-880S-150   | 1"                 | 6"    | 5.5"   | 0.56"        | 2"    | 0.69"        | 4               | 0.63"              | 3.13"                | 12                        | 0.17 |
| 1.5-880S-150 | 1.5"               | 7"    | 6.5"   | 0.69"        | 2.88" | 0.81"        | 4               | 0.63"              | 3.88"                | 22                        | 0.44 |
| 2-880S-150   | 2"                 | 7"    | 7.5"   | 0.75"        | 3.63" | 0.88"        | 4               | 0.75"              | 4.75"                | 29                        | 0.87 |
| 3-880S-150   | 3"                 | 8"    | 9.25"  | 1.0"         | 5"    | 1.13"        | 4               | 0.75"              | 6"                   | 50                        | 2.44 |
| 4-880S-150   | 4"                 | 10.5" | 11.75" | 1.0"         | 6.19" | 1.19"        | 8               | 0.75"              | 7.5"                 | 86                        | 5.84 |
| 6-880S-150   | 6"                 | 15.5" | 17.37" | 1.06"        | 8.5"  | 1.25"        | 8               | 0.88"              | 9.5"                 | 196                       | 18.9 |
| 8-880S-150   | 8"                 | 20.4" | 21.0"  | 1.25"        | 10.6" | 1.50"        | 8               | 0.88"              | 11.75"               | 380                       | 40.0 |

| BILL OF MATERIAL |           |          |              |             |
|------------------|-----------|----------|--------------|-------------|
| PART NUM.        | PART NAME | QUANTITY | MATERIAL     | ASTM NUMBER |
| 1                | BODY HALF | 2        | DUCTILE IRON | A-395       |
| 2                | LINER     | 2        | AS SPECIFIED | N/A         |
| 3                | BOLT      | *        | ALLOY STEEL  | A449        |
| 4                | NUT       | *        | ALLOY STEEL  | A194        |
| 5                | BALL      | 1        | PTFE         | N/A         |
| 6                | SPRING    | 1        | AS SPECIFIED | N/A         |

TOLERANCES:  
A AND B = ± 0.125"  
ALL OTHERS = ± 0.063"

\* - 1" AND 1.5" SIZES = 4  
2" THRU 8" SIZES = 8

|     |  |        |       |  |   |                                     |           |
|-----|--|--------|-------|--|---|-------------------------------------|-----------|
| 1   | ADDED 8" SIZE TO CHART, "LBS." TO TO WEIGHT, & TITLE | 7-8-06 | B.K.  | This drawing shall not be reproduced, copied, lent, disclosed, published, or disposed of, directly or indirectly, nor used for any purpose other than that for which it was specifically furnished | <b>ChemValve, Inc.</b><br>Tomball, Texas        |                                     |           |
|     |  |        |       |  | Model Number<br>880S-150-ASSEMBLY-DIMENSION-BOM |                                     |           |
|     |  |        |       |  | Drawn: B.K.                                     | Part Name<br>880S-150-ASSEM-DIM-BOM |           |
|     |  |        |       |  | Checked:  | Approved: B.K.                      | Rev.<br>1 |
| No. | Revision Description                                 | Date   | Chk'd |  | Date: 3-17-05                                   | 88S15-ASSEM-DIM-BOM                 |           |